

# Operating instructions



**AUTO BOOSTER**



(EN)	Operating Instructions .....	3 - 31
(DE)	Betriebsanleitung.....	32 - 60
(FR)	Notice d'utilisation .....	61 - 90
(NL)	Gebruiksaanwijzing .....	91 - 120
(ES)	Instrucciones de manejo .....	121 - 150
(IT)	Istruzioni sull'uso .....	151 - 180
(DA)	Bruksanvisning .....	181 - 208
(NO)	Bruksanvisning .....	209 - 238
(SV)	Brugsvejledning .....	239 - 268
(FI)	Käyttöohje .....	269 - 297
(CS)	Provozní návod .....	298 - 326
(PL)	Instrukcja obsługi.....	327 - 355
(HU)	Kezelési utasítás .....	356 - 384

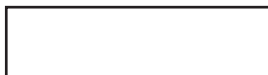
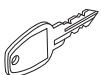

# Contents



<b>1</b>	<b>Safety Precautions and Warnings</b> .....	<b>4</b>
	Symbols used to mark instructions .....	4
<b>2</b>	<b>Description</b> .....	<b>6</b>
	2.1 Application .....	6
	2.2 Operation elements .....	6
<b>3</b>	<b>Installation</b> .....	<b>7</b>
	3.1 Temperature conditions .....	7
	3.2 Condition of distance .....	7
	3.3 Foundation / levelling .....	7
	3.4 Water connection .....	8
	3.5 Mains power connection .....	8
	3.6 Venting of HP-pump, fuel pump and detergent pumps .....	9
	3.7 Connecting to external fuel supply (AUTO BOOSTER D) .....	11
<b>4</b>	<b>Operation</b> .....	<b>12</b>
	4.1 Setting up the AUTO BOOSTER .....	12
	4.1.1 Coin operation .....	12
	4.1.2 Coin selector settings .....	12
	4.1.3 Teaching the coin selector to accept a coin .....	14
	4.1.4 Setting coin value on timer .....	15
	4.1.5 Maintenance of coin selector .....	16
	4.1.6 Programs and Program Selector .....	17
	4.1.7 Temperature setting .....	18
	4.1.8 Detergents A and B .....	19
	4.2 Running the AUTO BOOSTER .....	19
	4.2.1 Starting up .....	19
	4.2.2 Stopping the AUTO BOOSTER .....	20
	4.2.3 Programs .....	21
	4.2.4 Foam brush, mounting & dismounting .....	23
	4.2.5 Circulation frost protection .....	23
<b>5</b>	<b>Maintenance</b> .....	<b>24</b>
	5.1 Coin selector .....	25
	5.2 Hour counters .....	25
	5.3 Oil .....	26
	5.4 Water filter .....	26
	5.5 Cleaning of high pressure nozzle .....	27
	5.6 Fuel filter .....	27
	5.7 Disposable waste .....	27
<b>6</b>	<b>Trouble Shooting</b> .....	<b>28</b>
	6.1 General trouble shooting .....	28
	6.2 Error messages .....	29
<b>7</b>	<b>Technical Data</b> .....	<b>30</b>
<b>8</b>	<b>Warranty</b> .....	<b>31</b>
<b>9</b>	<b>Declaration of Conformity</b> .....	<b>31</b>

# EN 1 Safety Precautions and Warnings

DE

FR

## Symbols used to mark instructions

NL

ES

IT

DA

NO

SV

FI



This appliance is not intended for use by persons (including children) with reduced physical, sensory or mental capabilities, or lack of experience and knowledge.

High pressure cleaners shall not be used by children or untrained personnel.

Children should be supervised to ensure that they do not play with the appliance.

### Warning

Inhalation of aerosols can be hazardous to health. Where applicable use a device in order to avoid or reduce aerosols production, e.g., a shield covering the nozzle. For protection against aerosols use a respiratory mark of class FFP 2 or higher.

### General

When using the high-pressure hot water washer all existing national regulations must be observed. Beyond the instruction manual and the current



Before starting up your high-pressure washer for the first time, this instruction manual must be read through carefully. Save the instructions for later use.



Safety instructions marked with this symbol must be observed to prevent danger to persons.

national legal regulations for prevention of accidents, also the approved rules for safe working must be observed.

Any method of use endangering the safety of persons or equipment is forbidden.

### Before use

Before starting up your high-pressure hot water washer check that it is in a regular condition. Electric plugs and couplings must be watertight.

Check the electric cables at regular intervals for damage and wear. Only use the high-pressure hot water washer if the electric cable is all right (damaged electric cables can cause electric shock!)

### Important instructions

Connection to public drinking water supply must be performed in accordance with the applicable regulations in your country.

**IMPORTANT:** Only use water without impurities!



This symbol is used to mark safety instructions that must be observed to prevent damage to the machine and its performance.



This symbol indicates tips and instructions to simplify work and to ensure a safe operation.

Before each use of your high-pressure hot water washer check the most important visual parts.

High-pressure jets can be dangerous if misused. Never direct the water jet towards people, pets, electric wiring, or the machine itself.

Spray handle and lance are affected by a thrust during operation - therefore always hold the spray lance firmly with both hands.

Never try to clean clothes or footwear on yourself or other persons.

Operator and anyone in immediate vicinity of the site of cleaning should take action to protect himself from being struck by debris dislodged during operation.

Check that cleaning will not result in dangerous substances (e.g. asbestos, oil) being washed off the object to be



cleaned and harming the environment.

Do not clean sensitive surfaces made of rubber, fabrics or the like with the zero nozzle. With the flat jet nozzle keep a distance of at least 15 cm to the surface to be cleaned.

Do not use the machine if the electric cable or the high-pressure hose are damaged.

Do not cover the machine during operation or use it in a room without adequate ventilation !

If any of the machines overload protection devices trips (machine stops unintended), release the trigger of the spray handle. Lock the spray handle with locking device and turn the start/stop switch to position „OFF“.

Refer to section “6 Trouble Shooting”.

Never start the cleaner without water supply. Even a short water deficiency can damage the sleeves of the pump.

### Operation

Avoid damage to the electric cables such as squeezing, pulling, knots etc. and keep them away from sharp or hot objects.

Avoid damage to the high-pressure hose such as running over by vehicles, squeezing, pulling, knots/kinks etc. and keep it away from oil and sharp or hot objects, as such may cause the hose to burst.

The cleaner can be used in zones classified as ZONE 2.

**Important!** Never use the machine in an environment where there could be a danger of explosion (according to EN-50014).

**Important!** When the system has been in operation and thereafter stopped, there might

still be a working pressure in the pipeline and high-pressure hoses. Therefore you should pay special attention to the following:

- Never dismount the high-pressure hose from the machine during operation. Disconnect the machine and relieve the high-pressure hose of pressure prior to dismounting.
- Never dismount the high-pressure hose from the outlet point before it has been securely closed and the high-pressure hose has been relieved of pressure.
- Prior to any service interference in the machine it should be disconnected and the system relieved of pressure by activating the trigger of the spray handle.

### Repair and Maintenance

Only carry through the maintenance operations described in the operating instructions. Only use original Nilfisk-ALTO spare parts.

Do NOT make any technical modifications to the high-pressure hot water washer.

**Warning!** High-pressure hoses, nozzles and couplings are important for the safety when operating the machine. Only use the high-pressure hoses, nozzles and couplings prescribed by Nilfisk-ALTO! For major repairs, please contact your nearest Nilfisk-ALTO service organisation.

### Mains power connection

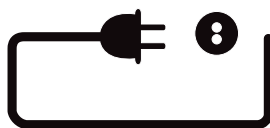

**This product is intended for stationary installation only and is supplied without a power cord! Only let an authorized electrician connect the machine to the mains**

### supply !

The following points must be observed:

- Check that the voltage stated on the data plate corresponds to your mains voltage.
- Make sure that the power cord contains the right number of wires (including ground wire) and that each wire has the right dimensions to carry the load (amperage) stated on the data plate of the machine.
- Make sure that the installation (cables, connection points and fuses) is correctly dimensioned for the load of the machine - refer to the data plate of the machine.

**If not required by local legislation, we strongly recommend you to connect the machine to a power source with a Residual Current Device (HPFI type B) which will disconnect the power supply if the leakage current exceeds 30 mA ! This Residual current device is necessary because of an inverter in the machine.**

See section “3.5 Mains power connection” for further instructions.

Only let a qualified electrician maintain the electric installation.

### Safety Devices

#### Safety Valve

The pressure side of the high-pressure pump is fitted with a safety valve. This valve leads the water back to the suction side of the pump when the spray handle is closed or if a nozzle is blocked.

The safety valve is adjusted and sealed by the producer. **THIS ADJUSTMENT MUST NOT BE CHANGED !**



EN

**Machine protection**

The machine features an over-current protection and built-in thermal protection of the motor. In the event of increased power consumption (maloperation) and in the event of excessive

motor temperature (obstructed ventilation etc.), the entire machine will automatically be disconnected from the mains supply.

*Short circuit protection*

The machine is equipped with a short-circuit protection. In the event of short-circuits in the machine, the protective device will disconnect and a manual reset is required.

DE

FR

NL

ES

IT

DA

NO

SV

FI

PL

CS

HU

## 2 Description

### 2.1 Application

This high-pressure hot water washer has been developed for stationary installation and self service operation within car washing

Section 4 describes how to use the high-pressure hot water washer.

Only use the high-pressure hot water washer for purposes described in this manual.

The safety precautions must be observed to prevent damage to the machine, the surface to be cleaned or severe personal injuries.

### 2.2 Operation elements

See foldout at the end of these operating instructions.



- |  |  |
|--|--|
| 1 Wash boom / high pressure hose                                 | 11 Water softening unit (option)           |
| 2 Main switch  | 12 Display (hour counters, error messages) |
| 3 Program selector switch  | 13 Brush holder                            |
| 4 Water inlet (only machines with optional water softening unit) | 14 Lance holder                            |
| 5 Thermostat (temperature adjustment) - AUTO BOOSTER E           | 15 Data plate                              |
| 5a Thermostat (temperature adjustment) - AUTO BOOSTER D          | 16 Lifting device                          |
| 6 Electric box   | 17 Coin selector                           |
| 7 Water tank   | 18 Assembly box, mains cable               |
| 8 Detergent container  | 19 "Free operation" switch                 |
| 9 Fuel container   | 20 Heating element, frost protection       |
| 10 Pressure gauge  | 21 Tap (accessory)                         |
|  | 22 No Scale, pump/container                |
|  | 23 Adjustment of detergent concentration   |
|  | 24 Inverter                                |



# 3 Installation

EN

DE

FR

NL

ES

IT

DA

NO

SV

FI

PL

CS

HU

## 3.1 Temperature conditions

The machine has been constructed for outdoor placement. The min. ambient temperature for the machine is  $-20^{\circ}\text{C}$  and the maximum ambient temperature is  $40^{\circ}\text{C}$ .

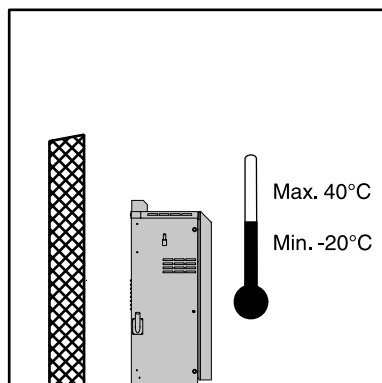

The hose, gun and lance are frost protected to  $-20^{\circ}\text{C}$  provided by circulation of preheated water through the system. The lance must be placed in the lance holder (14) after use in order to circulate the water in periods with frosty weather.

The machine features a fan heater automatically starting up when the temperature inside the machine gets too low.

The adjustment of the thermal sensor is effected in the electric box. On delivery the adjustment has been set at  $5^{\circ}\text{C}$ . This setting must not be lowered.

## 3.2 Condition of distance

In consideration of the cooling system of the machine and the accessibility of service, there must be free wall space on both sides of the machine. To the

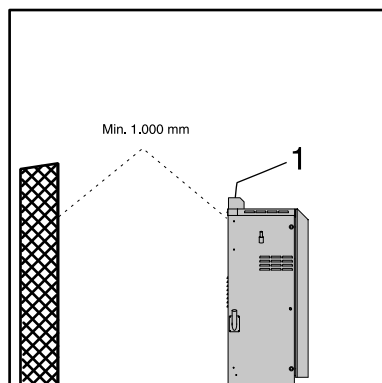
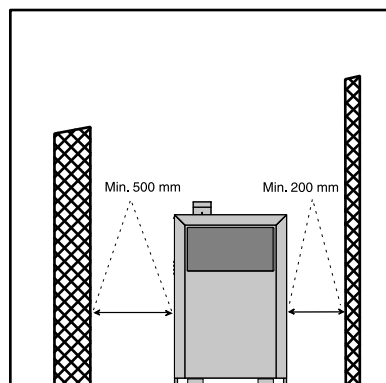

right 200 mm at a minimum, to the left 500 mm at a minimum and behind 300 mm.

The distance from the chimney outlet to inflammable material must be 1,000 mm. This distance can be reduced to 300 mm by mounting a diverter. You will find diverter and instructions for mounting in the front door.

The chimney (1) can be turned  $180^{\circ}$  by dismounting 4 pcs. M6 screws (under the top plate), turning the chimney and re-mounting the screws.

## 3.3 Foundation / levelling

Place the machine on a plane floor.

Bolt the machine to the foundation through the 3 holes ( $\text{Ø}12 \text{ mm}$ ) in the bottom plate. Before fastening, the machine must be levelled.

Shape of foundation, see foldout at the end of this manual.

EN

### 3.4 Water connection

The water connection is made with a flexible hose connected to the water tank (7) of the machine.

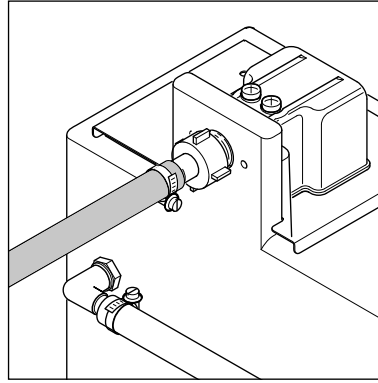

The water hose can be lead in through:

1. The bottom plate
2. The punch-out pieces in the rear plate

(see foldout at the end of this manual).

Make sure that the supply hose is suited for the purpose (temperature and flow rate). If in doubt, contact your Nilfisk-ALTO representative. Also ensure that the water supply hose is protected against freezing between the outlet and the AUTO

BOOSTER.

The connection can be made to a public drinking water supply network or a private water supply. Water quality: particle size <math><50 \mu</math>. A shut-off cock should be mounted on the water supply network in the immediate vicinity of the machine. Make sure that the water supply is within the following specifications and that the water does not contain particles such as floating sand.

Min. water inlet pressure: 1 bar (at the required flow rate of the machine - see data plate.

Max. water pressure: 10 bar

Max. water inlet temp.: 30°C.

All AUTO BOOSTER feature a water break tank, and no further protection against back-flowing water into the supply network is required. The machine complies with EN 60335-2-79.

If there is a risk of floating sand or other impurities in the inlet water, a sand filter (50 micron) should be mounted between the supply outlet and the internal filter of the machine.

### 3.5 Mains power connection

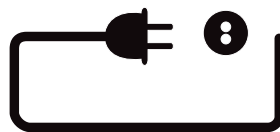

**CAUTION!** An authorized electrician must perform the electrical connection of the machine to the main power supply. Refer to section "1 Safety precautions and warnings".

**Do not forget installation of HPFI type B.**

The following precautions must be observed:

- Make sure that the supply cable is of the correct dimension (see voltage and load on the data plate of the machine (15)) and that it is suitable for the specific environment.





The electric cable can be lead in through:

1. The bottom plate
2. The punch-out pieces in the rear plate and through the relief ring into the junction box.

(see foldout at the end of this manual).

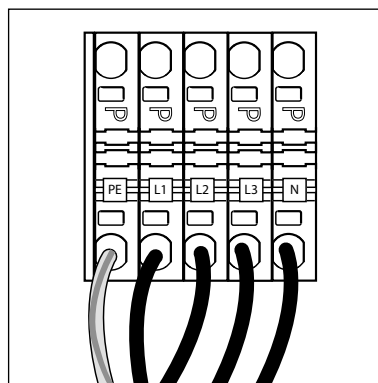

Assembly box, mains cable  
(see pos. 18 on foldout at the end of this manual)

- Connect the phase cords of the supply cable to the connection terminals L1, L2 and L3. Connect the neutral cord to N. For single phase machines use L1 and N to connect phase and neutral cords.

- Connect protective earth wire to the earthing terminal.
- Check and measure the protective earth connection according to legislation.
- Connect the other end of the cable to an approved plugged socket outlet of a correct dimensioned main supply.

All terminals are placed in junction box X2.

Make sure that the cable is properly guided and relieved between the fixed installation and the machine and that the cable is without any damage to the insulation.

Also see notes in section "1 Safety precautions and warnings"!



**Note:** Beware that the electric cables of the machine are not mixed up. The wires 1, 2, 3, 4 **MUST** keep the illustrated positions.

### 3.6 Venting of HP-pump, fuel pump and detergent pumps

When the AUTO BOOSTER is properly connected to supply water, electrical installation and the wash boom / high-pressure hose are fitted, the AUTO BOOSTER's hydraulic and fuel lines must be vented before it is operational.

- Set thermostat (5) to 40 °C. AUTO BOOSTER D: Adjustment on the side of the electric box. Temperature appears from display. Change of digital readout - press potentiometer.
- Fill fuel into the fuel container (9).
- Fill No Scale into the container (22).
- Fill detergent containers (8) with the appropriate detergents (see section 4.1.8).

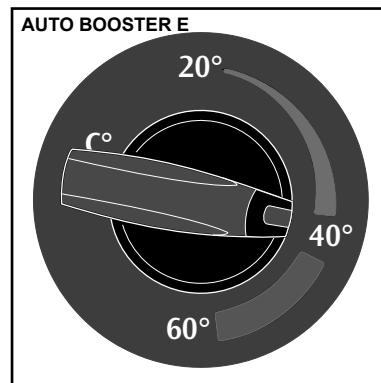
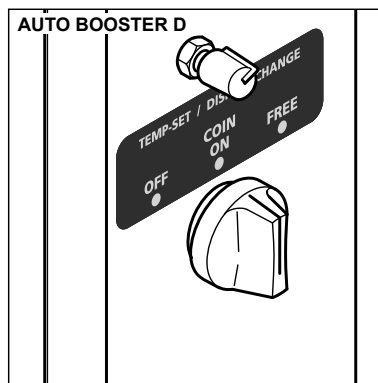

# AUTO BOOSTER

EN

DE

FR

NL

ES

IT

DA

NO

SV

FI

PL

CS

HU

- Open electric box (6) and set all Cold / Hot switches (S1, S2, S3, S4, S5) to "Hot" (= ON).
- Enable running without payment (19) (COINER FREE).
- Close electric box.

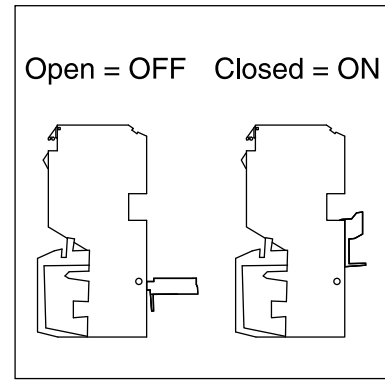
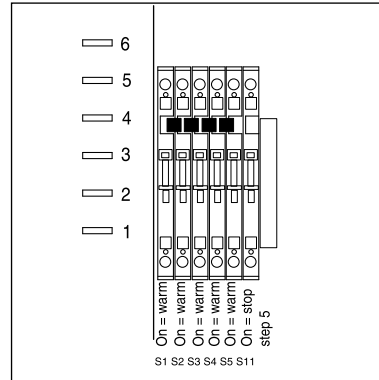

1. Turn the main switch, (2) to position "ON".
2. Activate the trigger of the spray handle on high-pressure hose, and turn the program selector switch (3) to program 1. The AUTO BOOSTER will start.

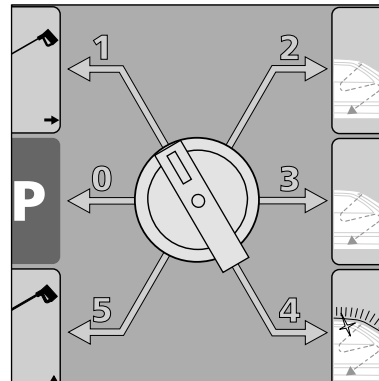

3. Let the water run until all air has escaped from the pump (even water flow), and check that the burner is running and detergent A is mixed into the water stream (foaming). Release the trigger of the spray handle.
4. Turn the Program selector to program 2 and activate the spray handle again. Observe that waterflow decreases (pressure drop). Then close spray handle.
5. Turn the Program selector to program 4. Activate the spray handle until a steady stream of detergent is seen in the water flow. Repeat step 3. Chemical pump B is now vented.
6. Stop the AUTO BOOSTER by turning the Selector switch to position STOP.

The AUTO BOOSTER is now vented and ready for use.



### 3.7 Connecting to external fuel supply (AUTO BOOSTER D)

The AUTO BOOSTER can be connected to an external fuel supply. As a standard, the machine is supplied with a 33 l container.

You can choose between “one” and “two” -string connection, where “one”-string only has one supply hose (a) and “two”-string has an additional return hose (b) - see figure.

Please observe the following restrictions to fuel line. Please observe that in some countries only the “one” string system is approved.

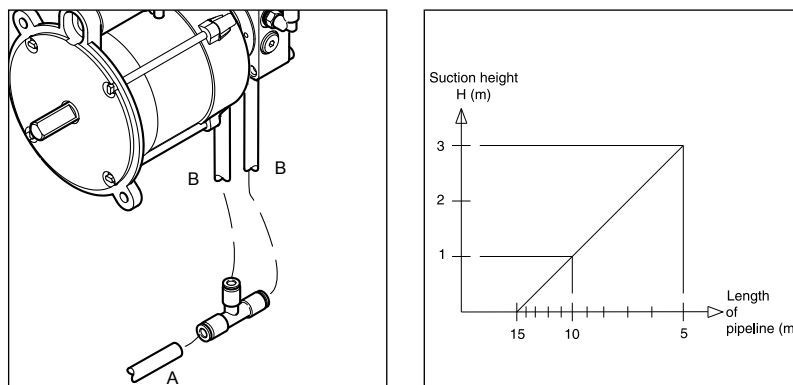

The fuel hose for the external fuel supply can be lead-in:

1. Through the bottom plate to the oil pump.
2. Through the punch-out pieces in the rear plate to the oil pump.

See foldout at the end of this manual.



# EN 4 Operation

DE

FR

NL

ES

IT

DA

NO

SV

FI

PL

CS

HU

## 4.1 Setting up the AUTO BOOSTER

The AUTO BOOSTER is designed as a user-friendly, self-service product, where the user can buy operation time to wash his vehicle.

Several features are adjustable by the owner, in order to provide a certain offering for a certain price.

- The owner must decide which payment to accept – coins of national currency and/or tokens,
- and how long washing time should be assigned to speci-

fic coins / tokens.

The AUTO BOOSTER provides 5 different program steps with the possibility to add 2 different detergents.

- The owner must decide if the individual program steps should run with hot or cold water.
- Also the detergent concentration of the 2 detergents must be determined within the range of Nilfisk-ALTO recommendations.

### 4.1.1 Coin operation

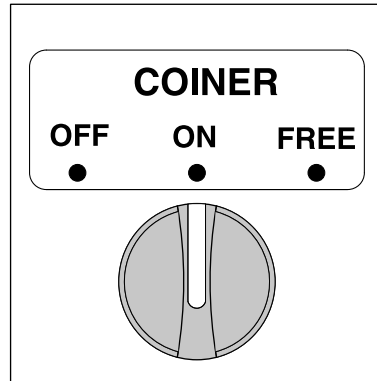

Normally the AUTO BOOSTER can only be started and used when appropriate payment is done.

- OFF:** Machine cannot be used. Coin will return.
- ON:** Normal operation. Coin selector active.
- FREE:** Machine can be used without inserting coins.

### 4.1.2 Coin selector settings

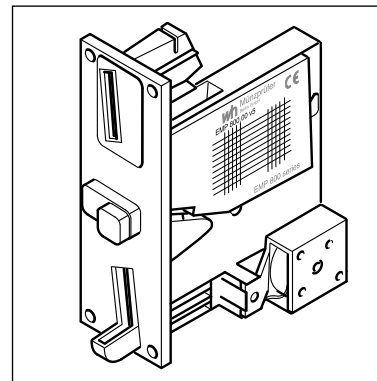

The coin selector (17) in the AUTO BOOSTER is European type, accepts €, £ and CHF and tokens

		Münzprüfer CE Dietmar Trenner GmbH IE // IP // IT									
		H H H H H X U					H H H H H X U				
0,50 EUR	1	.	4	7			2,00 GBP	3	.	6	10
1,00 EUR	2	.	5	7							
2,00 EUR	3	.	6	7		TK 11 A	11				11
1,00 CHF	1	.	4	9		TK 12 B	12				12
2,00 CHF	2	.	5	9		TK 13 C	13				13
5,00 CHF	3	.	6	9		TK 14 D	14				14
0,50 GBP	1	.	4	10		TK 15 E	15				15
1,00 GBP	2	.	5	10		TK 16 F	16				16

European type

The type is shown at the label on the side of the coin selector.

- (EN)
- (DE)
- (FR)
- (NL)
- (ES)
- (IT)
- (DA)
- (NO)
- (SV)
- (FI)
- (PL)
- (CS)
- (HU)

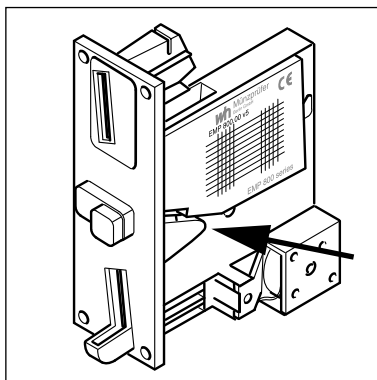

To ease access to the label and coin selector switches, the coin selector can be unclipped from the front panel.

Upon reception of the AUTO BOOSTER all the coins of the currencies listed on the label will be accepted.

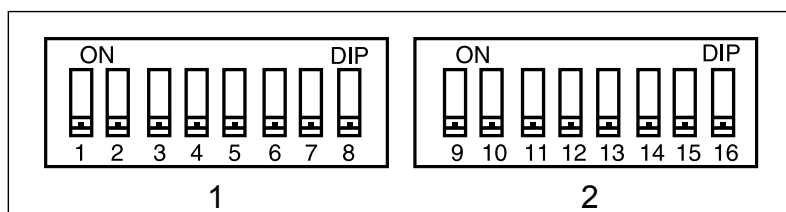
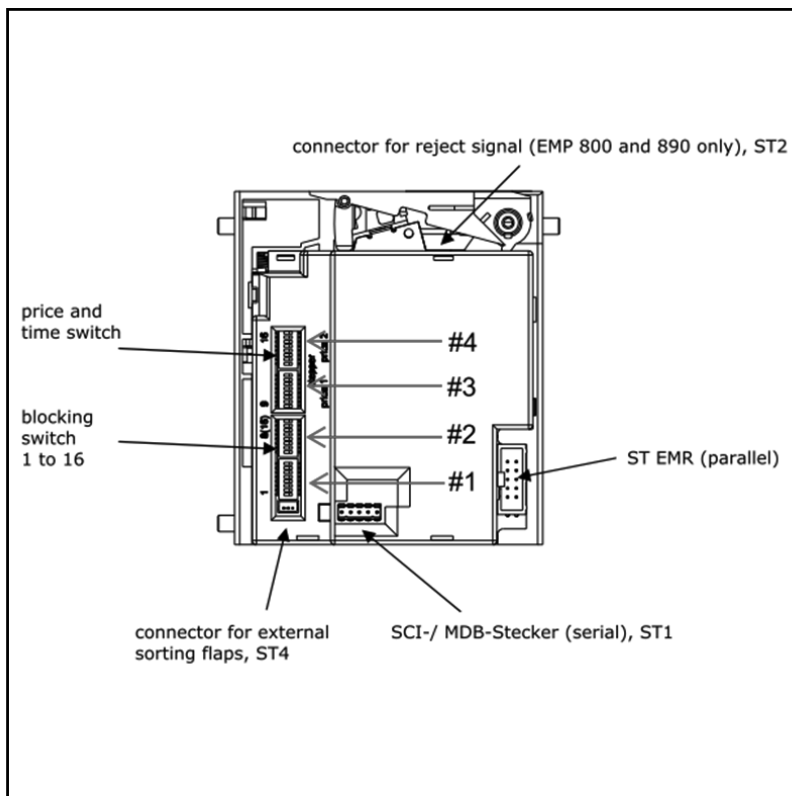

The owner can “block” coins of the currencies not valid in his country with the “blocking switches” on the side of the coin selector .

**European type:**

- Blocking switch 7 = “ON”, blocks all € - coins
- Blocking switch 9 = “ON”, blocks all CHF-coins
- Blocking switch 10 = “ON”, blocks all £ - coins

**Example:** An owner in Germany wants the AUTO BOOSTER coin selector to accept only € - coins.

- Blocking switch 7 must be in “OFF” position to accept € coins (0.50€ - 1.00€ - 2.00€).
- Blocking switches 9 and 10 must be “ON” to disable CHF and £ coins.

EN

DE

FR

NL

ES

#### 4.1.3 Teaching the coin selector to accept a coin

IT

DA

NO

SV

FI

PL

CS

HU

On both coin selectors the “Blocking switches 1,2,3,4,5,6” can further be used to disable coins of wide tolerances. For normal operation they should all be left in the “OFF” – position. The “Blocking switches 11,12,13,14,15,16” are all used only to teach the coin selector to recognize user defined coins. Leave these in “OFF”-position for now.

The Switch 8 is designated “Teach switch”. Leave this “OFF” for normal operation.

The coin selector can be “taught” to recognize and accept a user defined coin. The coin can be assigned one of six values by choosing one of six “Teach Channels”, represented by the blocking switches 11, 12, 13, 14, 15 and 16 (see 4.1.4)

Teaching is done by setting the coin selector to Teach Mode, selecting a “Teach Channel” and then entering a minimum of 10 coins through the coin slot.

Teaching can be performed with the coin selector in the machine.

Before beginning teaching

- Set coin switch (2) to OFF.
- Set blocking switches 11,12,13,14,15,16 on coin selector to OFF.
- Set teach switch 8 on coin selector to OFF.
- Set coin switch (19) back to ON.

Entering Teach Mode (in this example Teach Channel 13 is chosen)

- On coin selector set Teach Switch 8 ON to enter teach mode.
- On coin selector set blocking switch 13 – „TK13 C“ – to ON.

#### Teaching

- Enter Coin min. 10 times (use several coins/coins to have a better acceptance).
- On coin selector set blocking switch 13 back to OFF position. One single click from coin selector indicates that the Coin is accepted. (other indications: Coin not accepted – less than 10 entries or invalid coins - try again).
- Switch pin 8 back to OFF position.

The coin selector is now taught to recognize and accept the Coin as valid payment, and the value assigned to the Coin depends on the chosen Teach Channel (see 4.1.4).

Coins and national coins can be used simultaneously, when their blocking switches are OFF.



4.1.4 Setting coin value on timer

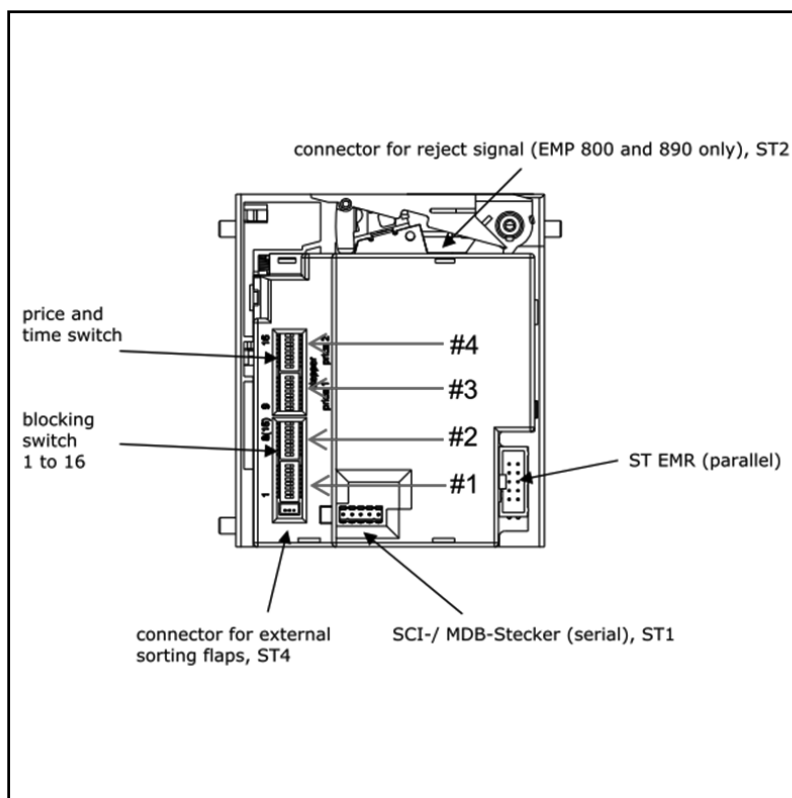

On the “Price Setting” switches # 3 choose the minimum price to be paid for the AUTO BOOSTER to operate.

On the “Time Setting” switches # 4 choose the time value you want to assign to the minimum price.

**Minimum price setting:**

Use pins to set minimum price to activate machine. See coin table and example following.

- EN
- DE
- FR
- NL
- ES
- IT
- DA
- NO
- SV
- FI
- PL
- CS
- HU

EN

See below table for coin selector:

Settings for Coin Selector			Price Setting: Select minimum price (basis for time setting)							
Coin type	Currency	Pulses	Minimum price switch							
			1	2	3	4	5	6	7	8
0,50	EUR	1	0,50	1,00	2,00	4,00	8,00	16,00	32,00	64,00
1,00	EUR	2								
2,00	EUR	4								
1,00	CHF	2								
2,00	CHF	4								
5,00	CHF	10								
0,50	GBP	1								
1,00	GBP	2								
2,00	GBP	4								
TK11	A	2	1	€	CHF	£				
TK12	B	4	2	€	CHF	£				
TK13	C	6	3	€	CHF	£				
TK14	D	8	4	€	CHF	£				
TK15	E	10	5	€	CHF	£				
TK16	F	12	6	€	CHF	£				

Time setting (Time / minimum price)								
1	2	3	4	5	6	7	8	
1	2	4	8	16	32	X10	Sec./Min.	

SW8 ON = Minutes, SW8 OFF = Seconds

**Example of setting in €-country:**  
**Owner wants 2,5 € to be inserted before machine can start:**  
 Flip SW1 & SW3 (0,50 € + 2,00 €) on "Minimum price switch" (# 3).

**Owner wants to assign 11 minutes to the minimum price 2.5 €:**  
 Flip SW1, SW2, SW4, SW8 (1+2+8+Sec./Min. = 11 Min.) on "Time Setting Switch" (# 4).  
 All other coin values will be adjusted proportionally by the timer - i.e. 1€ will be 240 sec's, or 4 minutes.

**Owner also wants to use a coin with an assigned value of 3 €:**  
 As 1 € corresponds to 2 impulses, 3 € equals 6 impulses - so owner teaches "TK13C" to recognize the coin (see how in sect. 4.1.3).

DE

FR

NL

ES

IT

DA

NO

SV

FI

PL

CS

HU

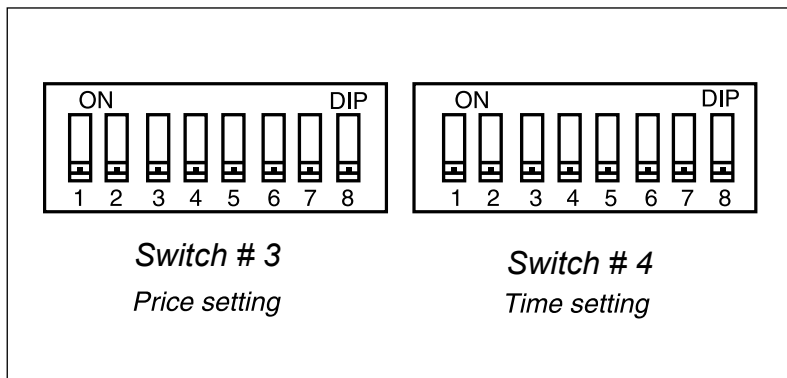

**Minimum price setting:**  
 Use pins to set minimum price

**Time setting:**  
 Use pins to set time value of minimum price.

**4.1.5 Maintenance of coin selector**

The coin selector should be cleaned at regular intervals especially if it is operating in an environment with high levels of dust, smoke or nicotine. The cleaning intervals are of course dependent on the level of air borne contaminants.

Modest use with minimum contaminant levels indicates the need to clean the top of the coin path once a year. Open the coin path door and wipe the exposed surfaces with an alcohol moistened cloth. The light sensors may be cleaned with a soft brush or air spray duster.



4.1.6 Programs and Program Selector

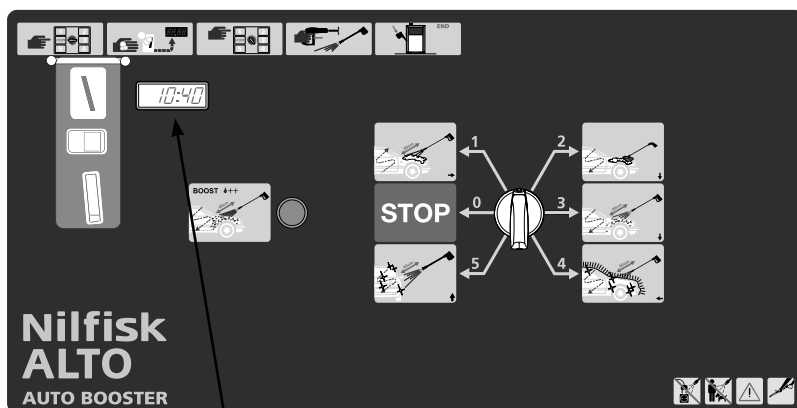

Indication of inserted payment followed by remaining time counting down when the minimum value has been reached

When payment is done, the user can choose freely between the AUTO BOOSTER's washing programs within the time paid for.

4 Programs without water softener (hard water)

Program	Description	Flow rate	Temp.	Detergent	Water	Memo
1	High pressure cleaning	100%	Hot	A (Super Plus / Auto Active)	Hard	
2	Foam brush	50%	Hot	A (Super Plus / Auto Active)	Hard	
3	Clear rinses	100%	Cold		Hard	
4	Gloss rinses	50%	Cold	B (Auto Dry)	Hard	
5	Gloss rinses	100%	Cold		Hard	Program blanked out with label

5 Programs with water softener (soft water)

Program	Description	Flow rate	Temp.	Detergent	Water	Memo
1	High pressure cleaning	100%	Hot	A (Super Plus / Auto Active)	Soft	Detergent (AA) (insect-solver ex. 2005)
2	Foam brush	50%	Hot	A (Super Plus / Auto Active)	Soft	
3	Clear rinses	100%	Cold		Soft	
4	Gloss rinses	50%	C or H	B (Active Wax)	Soft	
5	Gloss rinses	100%	Cold		Soft	

Above examples are from Germany on how the AUTO BOOSTER should work with only 4 program steps on hard water and 5 program steps on soft water. If wanted, hot or cold water can be chosen freely on any of the programs (selector inside electric box) and other detergents may be used.

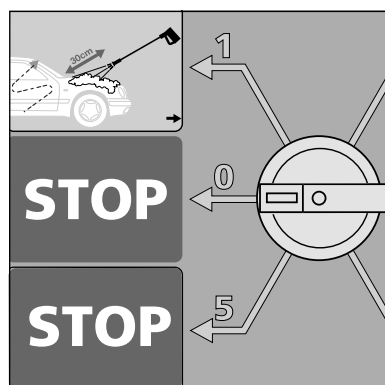

With soft water (<10 °dH) we recommend that you use 5 programs with the recommended Nilfisk-ALTO detergents.

For water hardness's between 10 °dh and 20 °dh you may choose either 4 or 5 programs with the recommended Nilfisk-ALTO detergents. Though for best cleaning result we recommend to install the "Water softening" option when choosing 5 programs.

If you choose to run with 4 program steps, we recommend that you exchange the "Active Wax" detergent with the "Auto Dry" in program 4. Program step 5 should not be used. Use the extra "STOP" sticker (in the plastic bag with coin labels) to blank program 5 on the front label. Deactivate Program 5 by setting switch S11 in off position.

If your water is hard (> 20 °dH) you must install a water softening unit (11).

- EN
- DE
- FR
- NL
- ES
- IT
- DA
- NO
- SV
- FI
- PL
- CS
- HU

# AUTO BOOSTER

EN

## 4.1.7 Temperature setting

DE

FR

NL

ES

IT

DA

NO

SV

FI

PL

CS

HU

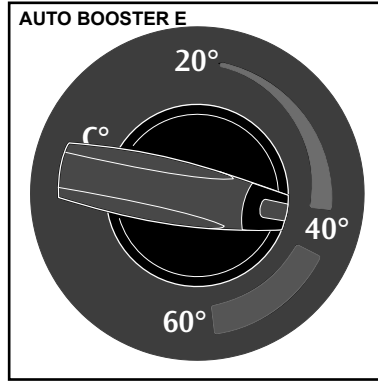
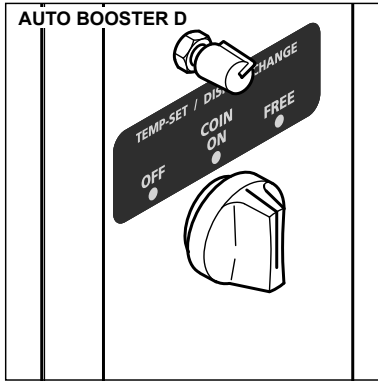

The overall setting of the hot water temperature, is done on the Thermostat (5) (max 60° C).

AUTO BOOSTER D: Adjustment on the side of the electric box. Temperature appears from display. Change of digital readout- press potentiometer.

Recommended temperature for car cleaning: 40°C.

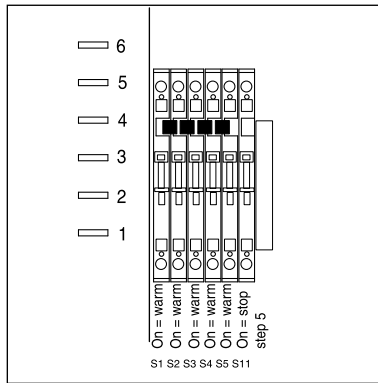

Each program step can be assigned either cold or hot (thermostat temperature) water, which is done on the 5 "Hot/Cold" switches S1, S2, S3, S4, S5 (one pr. program) located inside the electric box.

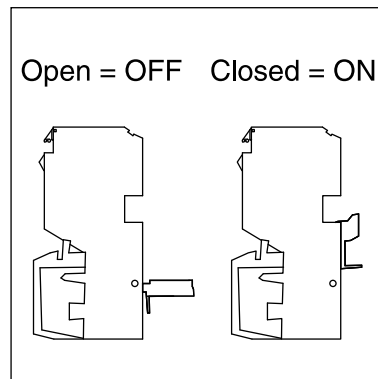

An Open switch assigns cold water.

A closed switch assigns hot water.



### 4.1.8 Detergents A and B

Nilfisk-ALTO's suggestions for detergent addition per program step:

#### 4 Programs, water hardness > 20° dH

Program	Description	Flow rate	Temp.	Detergent	Water
1	High pressure cleaning	100%	Hot	A (Super Plus / Auto Active)	Hard
2	Foam brush	50%	Hot	A (Super Plus / Auto Active)	Hard
3	Clear rinses	100%	Cold		Hard
4	Gloss rinses	50%	Cold	B (Auto Dry)	Hard
5	Gloss rinses	100%	Cold		Hard

#### 5 Programs, water hardness < 10° dH or water softener installed

Program	Description	Flow rate	Temp.	Detergent	Water
1	High pressure cleaning	100%	Hot	A (Super Plus / Auto Active)	Soft
2	Foam brush	50%	Hot	A (Super Plus / Auto Active)	Soft
3	Clear rinses	100%	Cold		Soft
4	Gloss rinses	50%	C or H	B (Active Wax)	Soft
5	Gloss rinses	100%	Cold		Soft

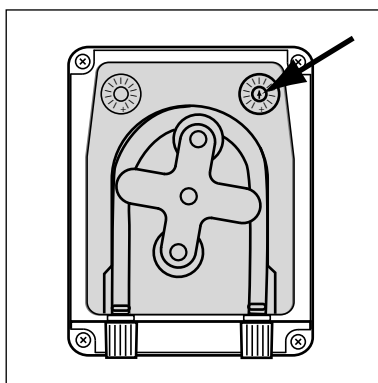

The concentration of detergent can be adjusted on the individual detergent pumps. The concentration of detergent in the water jet can be adjusted from 0 - 0.8 %.

## 4.2 Running the AUTO BOOSTER

### 4.2.1 Starting up

Prior to setting the AUTO BOOSTER into operation the entire machine should be properly vented, (section 3.7), and the settings of the paying system should be carried out (section 4.1.1 to 4.1.4).

1. Turn the main switch on the front of the electric box to position "ON".
2. Observe that the display next to the coin input is illuminated and shows "01:00" (if minimum value is set to 1).

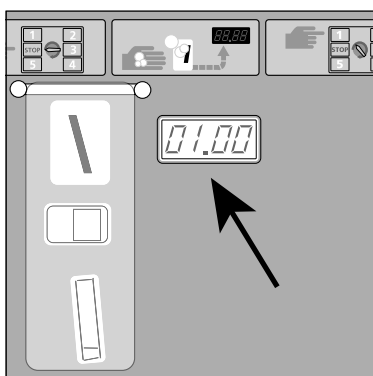

## AUTO BOOSTER

EN

DE

FR

NL

ES

IT

DA

NO

SV

FI

PL

CS

HU

3. Close the door of the AUTO BOOSTER, and lock the two key-locks.
4. Position the program selector switch (3) in position "STOP".
5. The AUTO BOOSTER is now operative.

By inserting valid coins or coins through the coin inlet, the display will show the payment, summing up as more coins are inserted.

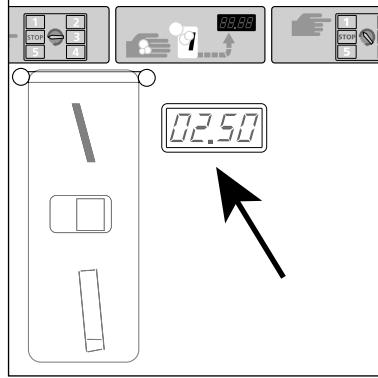

**!! NOTE:** The machine will start when the preset "minimum payment" has been reached. Insert of more coins will increase the time.

### 4.2.2 Stopping the AUTO BOOSTER



**!! NOTE:** In case of emergency turn the program selector switch (3) to STOP, or push the optional "Emergency Switch" !!

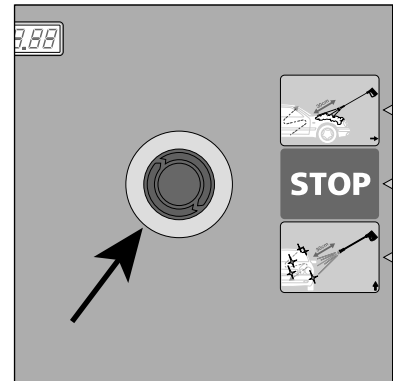
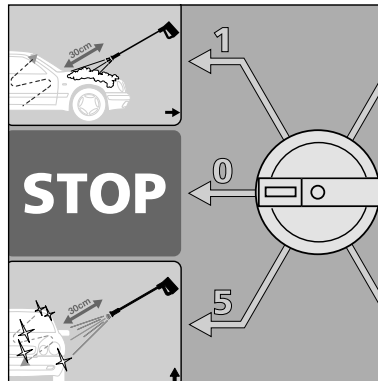

When pay time runs out (display at 00:00) the AUTO BOOSTER will automatically stop and relieve pressure from the hose/spray handle, no matter where the program selector switch is positioned.

If working is terminated for more than 90 seconds during pay-time (closed handle), the AUTO BOOSTER will enter standby mode, and the HP pump will stop. The boost button will start flashing. Working can be resumed by pressing the boost button, as long as pay time has not expired.



**!! NOTE:** Do not disconnect the AUTO BOOSTER from main power supply, neither by turning AUTO BOOSTERS main switch to position "OFF", nor by interrupting external installation switches as this will leave the AUTO BOOSTERS automatic frost protection device inoperative.



4.2.3 Programs

Running with soft water (< 15° dH) or with the optional “Water softening device” we recommend the following wash sequence for a medium size car:

EN

DE

FR

NL

ES

IT

DA

NO

SV

FI

PL

CS

HU

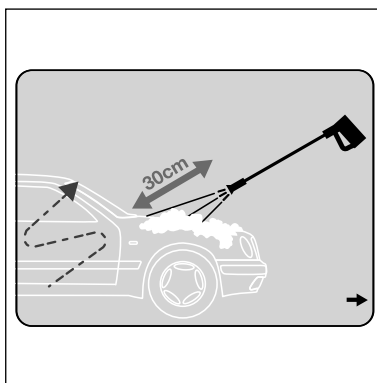

**Program 1** - (use approx. 3 minutes).

- Hot (or Cold), High pressure rinse with detergent “A”.

Move the lance along the car in a “Z” pattern, down-up, keeping the nozzle approx. 30 cm from the bodywork, rinsing away bigger particles as mud, salt, sand and insects.

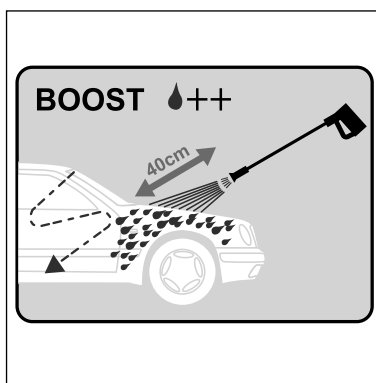

If there is a lot of sand, mud or salt, the boost function can be used.

Pressing the button, water volume and pressure will increase. No detergent. The function can be stopped by pressing the boost button again.

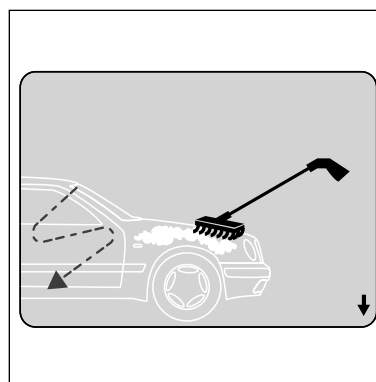

**Program 2** - (use approx. 6 minutes).

- Hot (or Cold), Low pressure rinse with foam brush and detergent “A”.

Attach the foam brush to the bayonet coupling of the lance (see 4.2.4), and brush-wash the car, removing traffic-film and “sticking objects”.

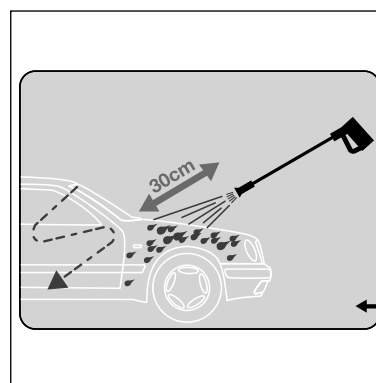

**Program 3** - (use approx. 2 minutes).

- Cold (or Hot) High pressure flushing without detergent.

Remove the foam brush (see 4.2.4.) and flush off all soap remainders.

EN

DE

FR

NL

ES

IT

DA

NO

SV

FI

PL

CS

HU

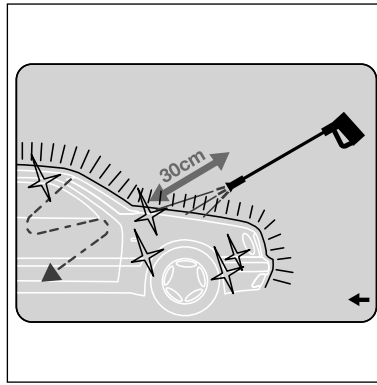

**Program 4** - (use approx. 3 minutes).

- Hot (or Cold) Conservation with wax, low pressure and detergent "B".

Apply wax over entire bodywork, and leave on for approx. 1 minute.

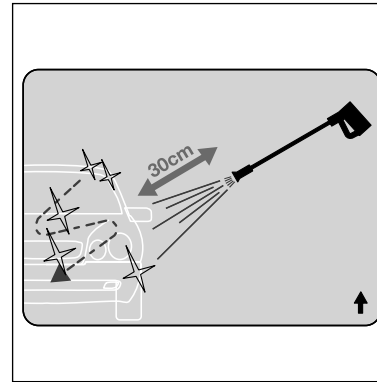

**Program 5** - (use approx. 2 minutes).

- Cold (or Hot) High pressure flushing without detergent. Flush off remainders of wax.

**STOP**

- Always place the Selector switch in this position when cleaning is completed.

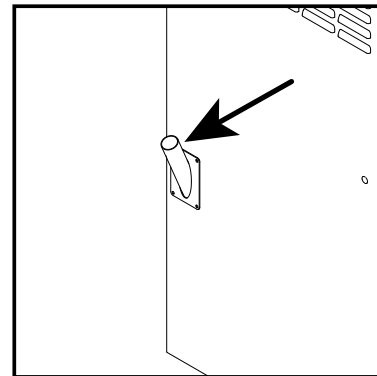

**NOTE:** The owner can individually assign hot or cold to each program step (section 4.1.7).

**NOTE:** Always place the lance in the lance holder, in order for the circulation frost protection system to work.

**Running with hard water (>15° dH) without the optional "Water softening device", the wax-conservation will not be of good quality. Thus we recommend that program step 5 is disconnected and turned into an extra STOP function by closing the switch S11 (OFF).**

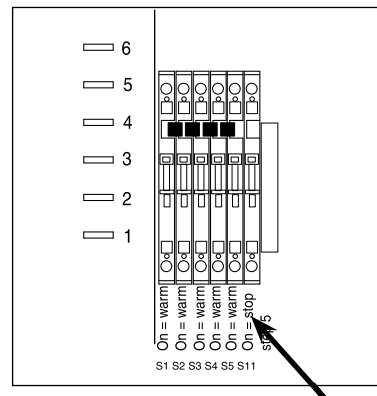

The "Active wax" detergent in container "B" must be replaced by the "Auto Dry" detergent (see sec. 4.1.6), and the wash sequence for a medium size car will be the same as in the previous programs 1, 2, 3, 4. Upon application of "Auto Dry" in program 4, do not rinse it off.

#### 4.2.4 Foam brush, mounting & dismounting

A soft foam brush is available for the AUTO BOOSTER to be used during program step 2.

On the left-hand side of the AUTO BOOSTER is placed a holder for storing the soft foam brush when not in use.

The soft foam brush is equipped with a female bayonet coupling that will accept the male bayonet coupling on the end of the spray lance.

Attach the brush to the lance by pushing the brush fully onto the lance (spring-loaded) and twist, until the bayonet couplings engage.

Remove the brush from the lance by reversing the above process.

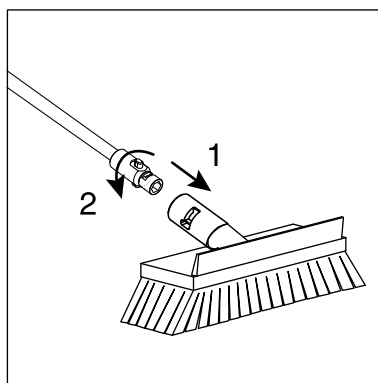

#### 4.2.5 Circulation frost protection

As standard the AUTO BOOSTER is equipped with a circulation device to protect the hose, the spray handle and the lance from freezing during periods with frost. Also, an internal, electrical heating element will prevent the machine itself from freezing. In order for the system to operate, the AUTO BOOSTER must not be disconnected from main electric supply (see note in sec. 4.2.1)

A thermostat switch mounted on the outside of the chassis of the AUTO BOOSTER switches ON the circulation frost protection system when the temperature is below the pre-set temperature.

Thus the pump starts circulating preheated water through the hose, spray handle and lance.

The lance must be placed in the holder at the left side of the AUTO BOOSTER in order to re-circulate the water (see note in sec. 4.2.3). If the lance is placed outside the holder, the water will spill on the ground at a rate of approximately 1 l/min.

An extra thermostat is located inside the cabinet of the AUTO BOOSTER to switch ON the electrical heating element in the cabinet, if the inside temperature drops below the pre-set temperature.



EN

DE

FR

NL

ES

IT

DA

NO

SV

FI

PL

CS

HU

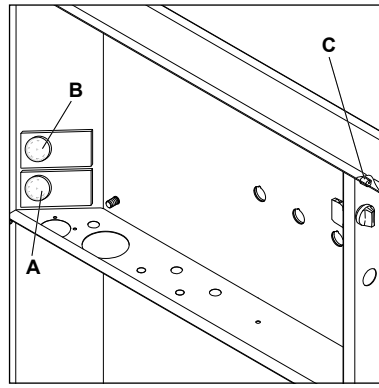

- A: Adjustment of temperature in the cabinet.
- B: Adjustment of temperature for start of circulation of water in hose, lance and handle (only E).
- C: Adjustment of temperature for start of circulation of water in hose, lance and handle (only D).

Adjust the temperature by pressing the Boost button for 4 sec. Now the value can be set on the potentiometer. Value can be read on the display. After adjustment, the water temperature (temperature for the user) must be adjusted too.

## 5 Maintenance

To ensure the most optimal maintenance of your auto BOOSTER, you should consider making a "Service Contract" with Nilfisk-ALTO. In this way your TRUCK BOOSTER will always be ahead of potential problems.

Though paying attention to a few things will ensure a prolonged and reliable operation of your AUTO BOOSTER.

Therefore it will be a good idea to follow the schedule of maintenance below. All times are intended as a guide and the maintenance should be made at more frequent intervals if required.

		Day	Week	Month	Year	Winter
Fuel	Check fuel level. Start machine and check that the boiler is working. If not, see section 3.7.	x				
Detergent	Check level in all detergent containers.	x				
Oil, high pressure pump	Check oil level. Refill if necessary. Send for a Nilfisk-ALTO service technician as soon as possible to have the cause of the oil consumption established.	x				
Coin collector	Empty coin collector.	x				
Washing brush	Check the washing brush for wear and impurities. Replace if necessary.	x				
Hose/lance	Check hose/lance for wear and leaks. Replace if necessary.		x			
Nozzle	Check spray picture. Clean the nozzle if necessary (see section 5.5).			x		
Water break tank	Empty the water break tank and clean it of impurities.				x	
Detergent / fuel containers	Empty the containers and clean them of impurities. Also clean the filters in the detergent containers.				x	





		Day	Week	Month	Year	Winter
Water softening unit (option)	Check the level of salt tablets. If necessary refill with salt tablets above the water level in the brine tank.		x			
Water softening unit (option)	Empty the brine tank and clean it.				x	
Water softening unit (option)	Check the setting of the timer. Adjust if necessary (see section 4.1.7).			x		
Water filter	Clean the water filter of the water break tank (see section 5.4) and the by-pass filter.			x		
Fuel filter	Replace fuel filter (see section 5.6).				x	
Lance holder	Check the lance holder for foreign bodies. If necessary, dismount it by loosening 4 bolts.					x
Frost protection	Check that the heating unit starts in the machine and that water is running through the lance when the temperature drops below the preset temperature.					x
Drain	Check the drain of the washing place.				x	
Outdoor thermostat	Clean the outdoor thermostat at the bottom of the front door with a dry cloth.					x
Locks	Lubricate locks with acid-free oil.				x	

- EN
- DE
- FR
- NL
- ES
- IT
- DA
- NO
- SV
- FI
- PL
- CS
- HU

**5.1 Coin selector**

See section 4.1.5.

**5.2 Hour counters**

Your AUTO BOOSTER features built-in hour counters that keep track of the number of working hours on your machine.

Change of digital readout - press the potentiometer.

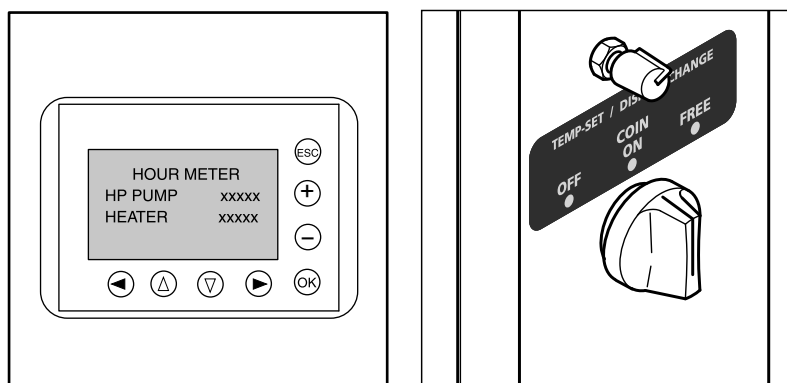

EN

5.3 Oil

Your AUTO BOOSTER is equipped with an electronic "oil sensor", which monitors the level of lubricant oil in the high-pressure pump. If the oil level (by malfunction or excessive wear) should drop to a low level, the pump will stop and the display shows "Pump oil level low".

Topping up the oil cup of the pump will be possible, but you should send for a Nilfisk-ALTO service technician as soon as possible to disclose the cause of the oil loss.

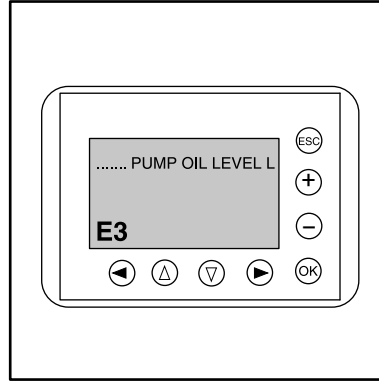

DE

FR

NL

ES

IT

DA

NO

SV

**PROTECT THE ENVIRONMENT**

Waste oil and oil sludge must be removed as laid down in the instructions.

FI

5.4 Water filter

To avoid debris entering the water break tank, water filters are fitted at the water inlet of the water break tank and at the by-pass return. Depending on the purity of the water, this filter will have to be cleaned at regular intervals.

The filter can be removed by unscrewing the union nut/container(1).

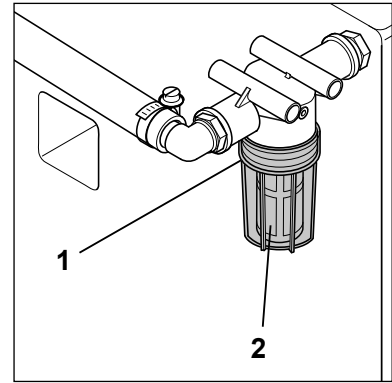
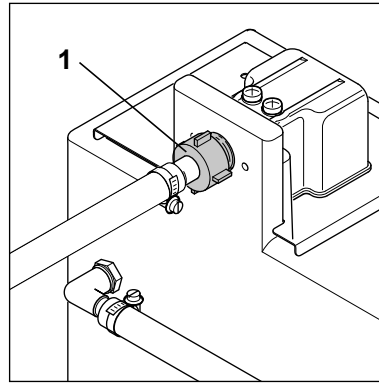

If the filter in the water inlet is clogged up by impurities, the machine will stop because of water shortage. The display will show "Water level low" "E10".

If the filter (2) in the by-pass return is clogged up, the water will overflow where the lance is stored on the machine (14).

Do not forget to turn off the water before cleaning the filter.

PL

CS

HU

### 5.5 Cleaning of high pressure nozzle



A clogging up in the nozzle will cause the pump pressure to increase above normal operating pressure, and cleaning of the nozzle is required immediately.

1. Stop the cleaner and detach the spray lance by loosening the screw on the quick connector.
2. Clean the nozzle with the cleaning tool.  
**IMPORTANT:** ONLY use the cleaning tool when the spray lance is detached.
3. Flush the spray lance backwards with water.
4. If the pressure is still too high, repeat items 1-3.

### 5.6 Fuel filter

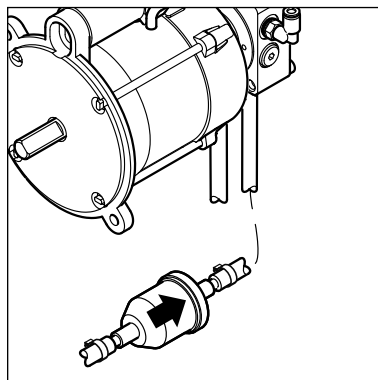

Open the door to gain access to the fuel pump.

If the filter on the suction side of the fuel pump is clogged up, it must be replaced.

### 5.7 Disposable waste

This high-pressure hot water washer consists of parts, which can affect the environment when thrown away. Parts that can pollute are as follows:

Oil, painted/zinc-coated parts, plastics/plastic-coated parts. Therefore, it is important to follow the laws concerning the removal of polluting and dangerous materials when replacing spare parts or disposing of high-pressure hot water washer.

It is recommended that you bring the rejected parts to waste disposal areas or recycling plants that are approved for the destruction of these types of materials.

EN

DE

FR

NL

ES

IT

DA

NO

SV

FI

PL

CS

HU

# EN 6 Trouble Shooting

You have chosen the best quality and therefore deserve the best service. The AUTO BOOSTER features an "Error detection system" that will stop the AUTO BOOSTER in case of a severe error that needs immediate attention. The display in the inspection window (12) will indicate the nature of the error.

Though the user can correct some of these errors, you should note the error and contact the nearest Nilfisk-ALTO service organization. To avoid unnecessary disappointments, you should check this section before contacting the nearest Nilfisk-ALTO service organization.

## 6.1 General trouble shooting

Symptom	Reason	Action
<b>Machine will not start</b> (NO ERROR indication)	<ul style="list-style-type: none"> <li>&gt; A fuse has blown</li> <li>&gt; Power disconnected</li> </ul>	<ul style="list-style-type: none"> <li>• Change the fuse.</li> <li>• Connect power (HPFI).</li> </ul>
<b>Fuses blow</b>	<ul style="list-style-type: none"> <li>&gt; Installation does not correspond to the ampere consumption of the machine</li> </ul>	<ul style="list-style-type: none"> <li>• Change to an installation corresponding to the ampere consumption of the machine at a minimum.</li> <li>• Change the fuse.</li> </ul>
<b>Working pressure too low</b>	<ul style="list-style-type: none"> <li>&gt; Nozzle worn</li> <li>&gt; Wrong spray lance</li> </ul>	<ul style="list-style-type: none"> <li>• Replace the nozzle.</li> <li>• Replace the spray lance (see section 4.1.4).</li> </ul>
<b>No detergent</b>	<ul style="list-style-type: none"> <li>&gt; Detergent container empty</li> <li>&gt; Filter in container clogged up</li> </ul>	<ul style="list-style-type: none"> <li>• Fill up with a detergent.</li> <li>• Clean the filter.</li> </ul>
<b>Working pressure fluctuating</b>	<ul style="list-style-type: none"> <li>&gt; Air in the system</li> <li>&gt; Detergent container empty</li> <li>&gt; Water inlet filter clogged up</li> </ul>	<ul style="list-style-type: none"> <li>• Vent the system (see section 3.7).</li> <li>• Fill up with a detergent.</li> <li>• Clean filter (see sect. 5.4).</li> </ul>
<b>No working pressure</b>	<ul style="list-style-type: none"> <li>&gt; Nozzle clogged up</li> <li>&gt; No inlet water</li> <li>&gt; Water inlet filter clogged up</li> </ul>	<ul style="list-style-type: none"> <li>• Clean nozzle (see sect. 5.5).</li> <li>• Check that the shut off cock of the water inlet is open. Check that the water supply meets the requirements (see section 3.4).</li> <li>• Clean filter (see sect. 5.4).</li> </ul>
<b>Machine starts and stops</b>	<ul style="list-style-type: none"> <li>&gt; Leaky hose/ pipeline/spray handle</li> <li>&gt; Water shortage</li> </ul>	<ul style="list-style-type: none"> <li>• Repair leak.</li> <li>• Check the water supply - open ? sufficient pressure ? Check and clean the water inlet filter (see sect. 5.4).</li> </ul>

## 6.2 Error messages

If your AUTO BOOSTER does not heat the water although heating has been chosen for the actual program step, the reason may be that the fuel container is empty or that one of the overheat melting fuses has blown/cut out. The two fuses are located at the top of the boiler and **MUST ONLY** be exchanged by an Nilfisk-ALTO service technician.

Error Message	Reason	Action
<b>Illegal sensor comb.</b>  <b>E1</b>	> Lack of water  > Defective or mal-adjusted flow sensor	<ul style="list-style-type: none"> <li>• Check your water supply – open?, sufficient pressure?</li> <li>• Check and clean inlet filter, (see sect. 5.4).</li> <li>• Call Nilfisk-ALTO service.</li> </ul>
<b>No flame detected</b>  <b>E5</b>	> No flame is detected when it should be present  > Fuel filter clogged  > Fuel container empty  > Flame sensor soothed or defective	<ul style="list-style-type: none"> <li>• Check your fuel supply, and refill is necessary.</li> <li>• Call Nilfisk -ALTO service.</li> <li>• Refill with fuel.</li> <li>• Call Nilfisk -ALTO service.</li> </ul>
<b>Illegal flame detected</b>  <b>E5</b>	> Flame detected when it should NOT be present  > Flame sensor defective	<ul style="list-style-type: none"> <li>• Flame sensor not mounted in place. Mount sensor.</li> <li>• Call Nilfisk -ALTO service</li> </ul>
<b>Pump oil level low</b>  <b>E3</b>	> Shortage of oil in high pressure pump	<ul style="list-style-type: none"> <li>• Top up with oil.</li> </ul>
<b>Water level low</b>  <b>E10</b>	> Lack of water in water tank	<ul style="list-style-type: none"> <li>• Check your water supply – open?, sufficient pressure?</li> <li>• Check and clean inlet filter, (see sect. 5.4).</li> </ul>
<b>Inverter error</b>  <b>E6</b>	> Cutting out of motor protection or thermal current in motor	<ul style="list-style-type: none"> <li>• Check of fan.</li> <li>• Check load of motor.</li> <li>• Check input voltage.</li> </ul>

Each time a fault is present, a counter will show the number of times the fault has been registered.

EN

DE

FR

NL

ES

IT

DA

NO

SV

FI

PL

CS

HU

# EN 7 Technical Data

DE

FR

NL

ES

IT

DA

NO

SV

FI

PL

CS

HU

Model		AUTO BOOSTER 5M-10/500 D NA5 NP2 coil	AUTO BOOSTER 5M-10/500 DS NA5 NP2 Coil	AUTO BOOSTER 5M-10/500 E NA5
Voltage	V	400	400	400
Number of phases		3	3	3
Frequency	Hz	50	50	50
Total current cons.	A	10.8	10.8	27
Power consumption	kW	6.4	6.4	16.8
Water connection:				
Max. pressure, inlet water	bar	10 / (6*)	10 / (6*)	10 / (6*)
Min. pressure, inlet water	bar	1.0	1.0	1.0
Max. temperature, inlet water	°C	30	30	30
Pump pressure	bar	100	100	100
Flow Qiec	l/h	500	500	500
Flow reduction	l/h	300	300	300
Heating tank, volume	liter	31	31	31
Spray lance:				
Nozzle type		.0370	.0370	.0370
Dimensions (H x W x D)	mm	1635x1090x725	1635x1090x725	1550x1090x725
Weight	kg	204	204	182
Pump oil type		BP Energol GR-XP220	BP Energol GR-XP220	BP Energol GR-XP220
Pump oil amount	l	0.7	0.7	0.7

\*) Applying to machines with the optional water softening equipment.

Sound pressure level  $L_{pA}$  measured in accordance with ISO 11202 [DISTANCE 1m] [FULL LOAD]: 69 dB(A).

We reserve the right to make alterations.

Diesel according to EN 590 (up to 7% bio diesel) can be used with the following restrictions:

Maximum storage time in high pressure cleaner diesel tank: 1 month.

Diesel stored externally for more than 6 months is not allowed to be filled into Nilfisk-ALTO high pressure cleaners.

Diesel EN 590 is not recommended for use in HPW's at an ambient temperature below 0°C.

Diesel EN 590 from an open container must not be used.

# 8 Warranty

Your Nilfisk-ALTO product is guaranteed for 12 months from date of purchase (purchase receipt must be presented) on the following conditions:

- that defects are attributable to flaws or defects in materials or workmanship. (Usual wear and tear as well as misuse are not covered by the guarantee).
- that repairs have not been carried out or attempted by other than Nilfisk-ALTO-trained service staff.
- that only original accessories have been applied.
- that the product has not been exposed to abuse such as knocks, bumps or frost.
- that the instructions in the manual have been carefully observed.

A warranty repair comprises the replacement of defective parts, but it does not cover freight and packaging charges. Besides we refer to national Sale of Goods Act.

Any **illegitimate** guarantee repair will be invoiced. (I.e. malfunctions due to **causes** mentioned in section “6 Trouble shooting” of the instruction manual).

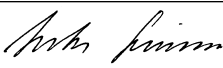

# 9 Declaration of Conformity

 <b>Declaration of Conformity</b>	
<b>Product:</b>	High Pressure Washer
<b>Type:</b>	AUTO BOOSTER
<b>Description:</b>	400 V 3~ 50 Hz - 230 V 1~, 50 Hz - IP X5
<b>The design of the unit corresponds to the following pertinent regulations:</b>	EC Machine Directive 2006/42/EC EC Low-voltage Directive 2006/95/EC EC EMC Directive 2004/108/EC RoHS Directive 2011/65/EC Noise Directive 2000/14/EC
<b>Applied harmonised standards:</b>	EN 60335-2-79 (2012), EN 55014-1 (2006), EN 61000-3-3 EN 55014-2 (2001), EN 61000-3-2 (2006)
<b>Applied international standards and technical specifications:</b>	IEC 60335-2-79 (2012)
<b>Name and address of the person authorised to compile the technical file:</b>	Anton Sørensen General Manager, Technical Operations EAPC  Nilfisk-ALTO Division of Nilfisk-Advance A/S Industrivej 1 DK-9560 Hadsund
<b>Identity and signature of the person empowered to draw up the declaration on behalf of the manufacturer:</b>	  Anton Sørensen General Manager, Technical Operations EAPC  Nilfisk-ALTO Division of Nilfisk-Advance A/S Industrivej 1 DK-9560 Hadsund
<b>Place and date of the declaration:</b>	Hadsund, 01.09.2013

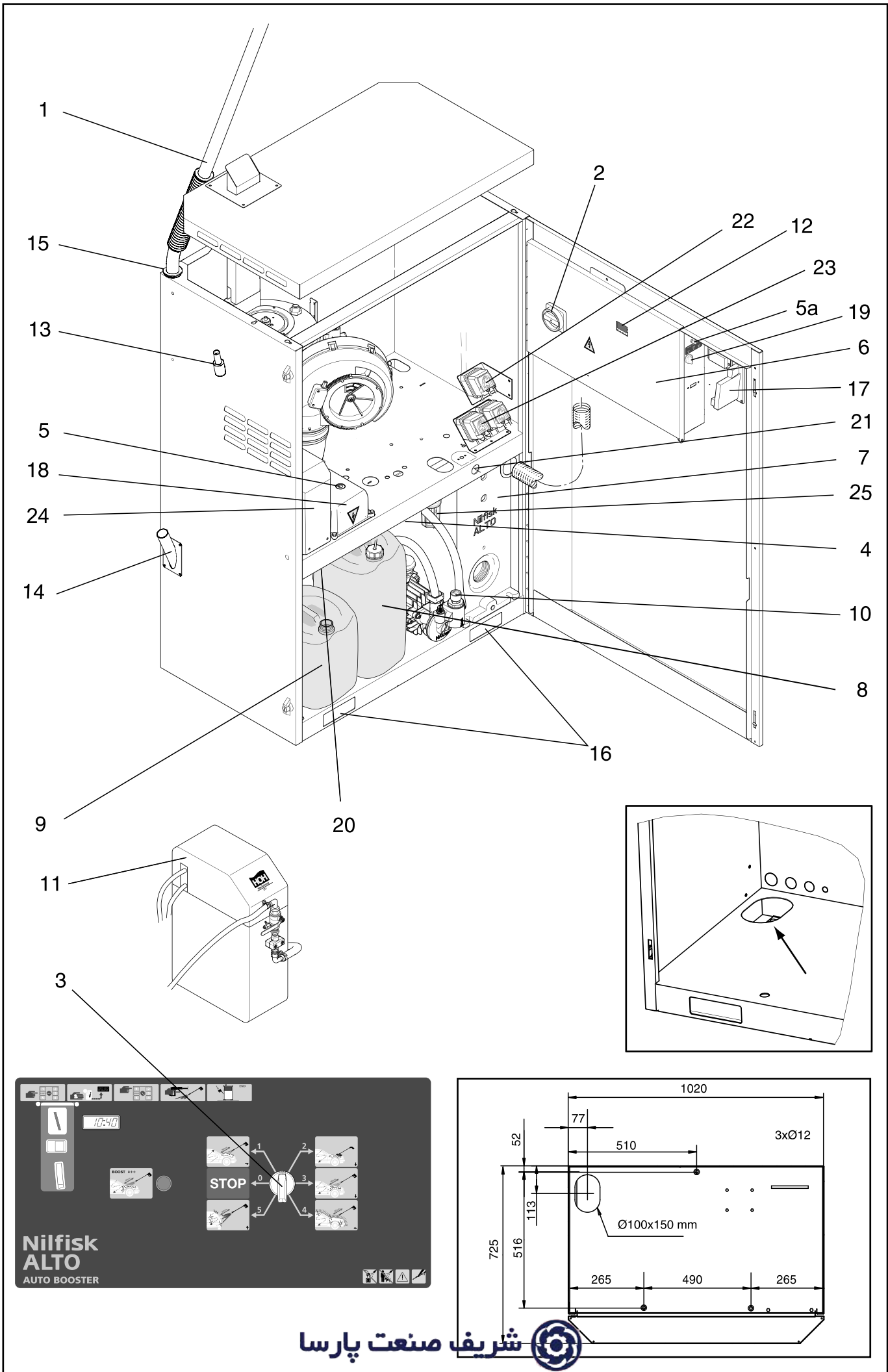



# Nilfisk ALTO

works for you

## HEAD QUARTER

### DENMARK

Nilfisk-Advance A/S  
Sognevej 25  
DK-2605 Brøndby  
Tel.: (+45) 4323 8100  
www.nilfisk-advance.com

## SALES COMPANIES

### ARGENTINA

Nilfisk-Advance srl.  
Herrera 1855, 6 floor, Of. A-604  
ZC 1293 – Ciudad Autónoma  
de Buenos Aires – Argentina  
www.nilfisk-alto.com

### AUSTRALIA

Nilfisk-ALTO  
Unit 1, 13 Bessemer Street Blacktown  
NSW 2148 Australia  
www.nilfisk-alto.com.au

### AUSTRIA

Nilfisk-ALTO  
Geschäftsbereich der Nilfisk-Advance GmbH  
Metzgerstraße 68  
A-5101 Bergheim/Salzburg  
www.nilfisk-alto.at

### BELGIUM

Nilfisk-Advance NV/SA  
Riverside Business Park  
Boulevard Internationalelaan 55  
Bâtiment C3/C4 Gebouw  
Bruxelles 1070 Brussel  
www.nilfisk.be

### CHILE

Nilfisk-Advance S.A.  
San Alfonso 1462, Santiago  
www.nilfisk.com

### CHINA

Nilfisk-Advance Cleaning Equipment  
(Shanghai) Co Ltd.  
No. 4189, Yindu Road  
Xinzhuang Industrial Park  
Shanghai 201108  
www.nilfisk.cn

### CZECH REPUBLIC

Nilfisk-Advance s.r.o.  
Do Certous 1  
VGP Park Horní Pocerence, Budova H2  
CZ-190 00 Praha 9  
www.nilfisk.cz

### DENMARK

Nilfisk-ALTO Danmark  
Industrivej 1  
Hadsund, DK-9560  
www.nilfisk-alto.dk

### FINLAND

Nilfisk-Advance OY Ab  
Koskelontie 23E  
Espoo, FI-02920  
www.nilfisk.fi

### FRANCE

Nilfisk-Advance SAS  
Division ALTO  
BP 246  
91944 Courtaboeuf Cedex  
www.alto-fr.com

### GERMANY

Nilfisk-ALTO  
Geschäftsbereich der Nilfisk-Advance AG  
Guido-Oberdorfer-Straße 10  
89287 Bellenberg  
www.nilfisk-alto.de

### GREECE

Nilfisk-Advance A.E.  
8, Thoukididou Str.  
Argiroupoli, Athens, GR-164 52  
www.nilfisk.gr

### HOLLAND

Nilfisk-Advance B.V.  
Versterkerstraat 5  
1322 AN ALMERE  
www.nilfisk.nl

### HONG KONG

Nilfisk-Advance Ltd.  
2001 HK Worsted Mills Ind'l Bldg.  
31-39 Wo Tong Tsui St.  
Hong Kong, Kwai Chung, N.T.  
www.nilfisk.com

### HUNGARY

Nilfisk-Advance Kereskedelmi Kft.  
H-2310 Szigetszentmiklós-Lakihegy  
II. Rákóczi Ferenc út 10.  
www.nilfisk.hu

### INDIA

Nilfisk-Advance India Limited  
Pramukh Plaza, 'B' Wing, 4th floor, Unit No. 403  
Cardinal Gracious Road, Chakala  
Andheri (East), Mumbai 400 099  
www.nilfisk.com

### IRELAND

Nilfisk-Advance  
1 Stokes Place  
St. Stephen's Green  
Dublin 2, Ireland  
www.nilfisk-alto.ie

### ITALY

Nilfisk-Advance S.p.A.  
Strada Comunale Della Braglia, 18  
Guardamiglio, Lombardia, I-26862  
www.nilfisk.it

### JAPAN

Nilfisk-Advance Inc.  
1-6-6 Kita-Shinyokohama  
Kouhoku-Ku  
Yokohama 223-0059  
www.nilfisk-advance.co.jp

### KOREA

Nilfisk-Advance Korea  
471-4, Kumwon B/D 2F,  
Gunja-Dong, Gwangjin-Gu, Seoul  
www.nilfisk-advance.kr

### MALAYSIA

Nilfisk-Advance Sdn Bhd  
SD 33, Jalan KIP 10  
Taman Perindustrian KIP  
Sri Damansara  
52200 Kuala Lumpur  
Malaysia  
www.nilfisk.com

### MEXICO

Nilfisk Advance de Mexico S. de R.L. de C.V.  
Agustin M. Chavez 1, PB-004  
Col. Centro Ciudad Santa Fe  
C.P. 01210 México, D.F.  
www.nilfisk-advance.com.mx

### NEW ZEALAND

Nilfisk-Advance NZ Ltd  
Danish House  
6 Rockridge Avenue  
Penrose Auckland NZ 1135  
www.nilfisk.com.au

### NORWAY

Nilfisk-Advance AS  
Bjørnerudvejen 24  
Oslo, N-1266  
www.nilfisk-alto.no

### POLAND

Nilfisk-Advance Sp. z o.o.  
ul. 3-go Maja 8, Bud. B4  
Pruszków, PL-05-800  
www.nilfisk-alto.pl

### PORTUGAL

Nilfisk-Advance, Lda.  
Sintra Business Park  
Zona Industrial Da Abrunheira  
Edificio 1, 1o A  
Sintra, P-2710-089  
www.nilfisk.pt

### RUSSIA

Nilfisk-Advance LLC  
Vyatskaya str. 27, bld. 7, 1st floor  
Moscow, 127015  
www.nilfisk.ru

### SOUTH AFRICA

WAP South Africa (Pty) Ltd  
12 Newton Street  
1620 Spartan, Kempton Park  
www.wap.co.za

### SINGAPORE

Nilfisk-Advance Pte Ltd  
22 Tuas Avenue 2  
Singapore 639453  
www.nilfisk.com

### SPAIN

Nilfisk-Advance, S.A.  
Torre D'Ara  
Passeig del Rengle, 5 Pta. 10ª  
Mataró, E-0830222  
www.nilfisk.es

### SWEDEN

Nilfisk-ALTO  
Aminogatan 18  
Möndal, S-431 53  
www.nilfisk-alto.se

### SWITZERLAND

NA Sondergger AG  
Nilfisk-ALTO Generalvertretung  
Mühlestrasse 10  
CH-9100 Herisau  
www.nilfisk-alto.ch

### TAIWAN

Nilfisk-Advance Ltd.  
Taiwan Branch (H.K.)  
No. 5, Wan Fang Road, Taipei  
www.nilfisk-advance.com.tw

### THAILAND

Nilfisk-Advance Co. Ltd.  
89 Soi Chochechai-Ruammitr  
Viphavadee-Rangsit Road  
Jomphol, Jatuchak  
Bangkok 10900  
www.nilfisk.com

### TURKEY

Nilfisk-Advance A.S.  
Şerifali Mh. Bayraktar Bulv. Sehit Sk. No:7  
Ümraniye, Istanbul 34775  
www.nilfisk.com.tr

### UNITED KINGDOM

Nilfisk-ALTO  
Bowerbank Way, Gilwilly Industrial Estate  
Penrith, Cumbria  
GB-CA11 9BQ  
www.nilfisk-alto.co.uk

### UNITED ARAB EMIRATES

Nilfisk-Advance Middle East Branch  
SAIF-Zone, P. O. Box 122298  
Sharjah  
www.nilfisk.com

### USA

Nilfisk-Advance  
14600 21st Ave. North  
Plymouth MN 55447-3408  
www.nilfisk-alto.us

### VIETNAM

Nilfisk-Advance Co., Ltd.  
No.51 Doc Ngu Str, Lieu Giai Ward  
Ba Dinh Dist. Hanoi  
www.nilfisk.com